

### Classified according to IEC 61400-12-1 Edition 2.0 (2017-03)

The Thies FCA X Anemometer has the best classification values on the market. Its built-in pressure sensor automatically corrects the wind speed measurement depending on air pressure.

The new low power version now has an even lower consumption (typ. 14 mA at 12 V) in IEC classified mode and up to eight sensors can be connected in a single bus.

Since the old version uses the same communication protocol as the new one, they can be used in the same bus.



### Intelligent optically-scanned cup anemometer

Thies First Class Advanced X is classified acc. to IEC 61400-12-1 Ed. 2.0 (2017-03). It has been designed to measure:

- Horizontal wind speed
- Absolute and relative air pressure
  
- Inclination X, Y and Z
- Acceleration, frequency and amplitude of vibration measurement in X, Y and Z

The anemometer is designed for measuring of wind resources for assessment reports and power curves. The sensor is characterized by minimal deviation from cosine line, optimized dynamic behavior even at highly intense turbulences, minimal overspeeding, low starting value and optimized oblique inflow behavior. It requires only low maintenance thanks to its low-inertia and ball-bearing cup star. For winter operation the electronically regulated heating guarantees smooth running of the ball bearings and prevents icing of shaft and slot.

### Intelligent correction of measurement values

The sensor integrates an automatic correction of the wind speed measurement value depending on air pressure. The revolutions per minute (rpm) of the cup star depend on air density and thus on air pressure. The correction is implemented for 700 ... 1100 hPa. The anemometer output covers both original and corrected measurement values.

### Calibration

For wind resource assessment, anemometers have to be calibrated acc. to MEASNET. Thies First Class Advanced X can save slope and offset values determined during calibration. Thus no further corrections have to be made. We recommend calibrating anemometers in the wind tunnel of Ammonit Wind Tunnel GmbH ([ammonit-windtunnel.com](http://ammonit-windtunnel.com)).

**Configuration of counter output to be in IEC classified mode**

When the anemometer is configured with the parameter FO = 4 then the counter output gives the air pressure corrected wind speed output which obtained the IEC classification result described below.

$$\text{wind speed [m/s]} = 0,1 [\text{m}] \times f [\text{Hz}]$$

**Low power configuration of sensor fulfilling the IEC classified mode (Heating OFF)**

Per default we deliver the sensor in a configuration which is at the same time low power and IEC classified (Heating OFF).

If you do not have large power resources in your measurement campaign (especially offgrid) we recommend you to keep this default configuration.

Then both the counter and the serial output give the air pressure corrected wind speed output which obtained the excellent IEC classification result (Heating OFF), but at the same times keeps a low power consumption (typ. 14 mA at 12 V).

**S Classification value for warm climate countries**

Please note that if your measurement campaign takes place in a country with a warm climate (no season below 10°C), then the S classification value for this climate matches the IEC classified mode (Heating ON) even if the sensor is configured in low power mode.

**High power configuration of sensor to be in IEC classified mode (Heating ON)**

If you have large power resources available in your measurement campaign (up to 20W available per anemometer), and you have climate with cold winter, then please inform us, we will configure the sensor in order that it fulfils the IEC classified mode (heating ON).

Please note that you will need to take the version S11200H (heating version) and a special cable with heating cores.



### Classification acc. to IEC 61400-12-1 Edition 2.0 (2017-03)

The direct influence of air density was measured using a specially designed variable air density wind tunnel, instead of calculating the influence of air density by using torque measurements.

	Class A	Class B	Class C	Class D
Heating ON	0.65	0.9	0.7	0.9
Heating OFF	1.1	1.8	3.3	3.3

Source: Summary report AK 151023-1.1 Cup Anemometer Classification, Deutsche WindGuard Tunnel Services GmbH, Varel, Germany, 2017.

### Operational standard uncertainty acc. to IEC 61400-12-1

The operational standard uncertainty describes the maximum deviation of the wind speed measured by the anemometer compared with the real wind speed. The table indicates the operational standard uncertainty at 10 m/s:

	Class A	Class B	Class C	Class D
Heating ON	0.04 m/s	0.05 m/s	0.04 m/s	0.05 m/s
Heating OFF	0.06 m/s	0.10 m/s	0.19 m/s	0.19 m/s

### Linearity (MEASNET)

The MEASNET required linearity for anemometers is  $r > 0.999\ 95$ .  
The Thies First Class Advanced II offers  $r > 0.999\ 99$  (4 ... 20 m/s).

### Dimensional drawing

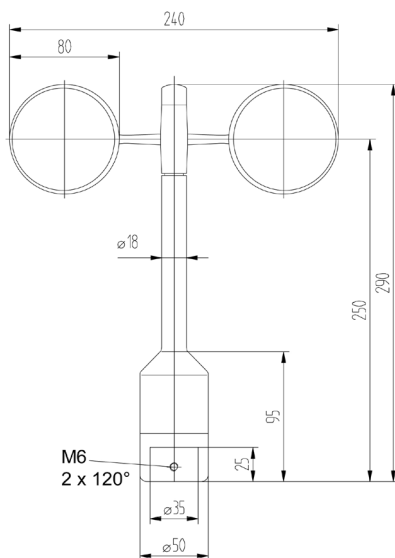

**Specification**

<b>Characteristics</b>	
Physical functionality	Optically-scanned cup anemometer
Delivered signal	Frequency output (pulse) and RS485 (Modbus RTU)
<b>Accuracy</b>	
Accuracy wind speed	$\pm 1\%$ of measured value or $< \pm 0.2$ m/s @ 0.3 ... 50 m/s
Accuracy housing temperature	$\pm 1^\circ\text{C}$ (Measurement range: $-40 \dots +80$ °C)
Accuracy air pressure	$\pm 1$ hPa @ 20°C (Measurement range: 300 ... 1100 hPa)
Accuracy inclination (X, Y, Z)	$\pm 1^\circ$ (Measurement range: $-89.9^\circ \dots +89.9^\circ$ )
Accuracy vibration (X, Y, Z)	$\pm 0.4$ Hz (Measurement range: 0 ... 50 Hz)
Accuracy acceleration	$\pm 30$ mg (Measurement range: $\pm 8$ g)
Linearity	Correlation factor $r$ between frequency $f$ and wind speed $y$ $r > 0.99999$ (4 ... 20 m/s)
Starting velocity	$< 0.3$ m/s
Resolution	0.05 m wind run
Distance constant	$< 3$ m (acc. to ASTM D 5096 - 96) 3 m acc. to ISO 17713-1
Turbulent flow into cups	Deviation $\Delta v$ turbulent compared with stationary horizontal flow $-0.5\% < \Delta v < +2\%$ Frequency $< 2$ Hz
Wind load	Approx. 100 N @ 75 m/s
<b>Operating range</b>	
Measuring range	0.3 ... 75 m/s
Survival speed	80 m/s (mind. 30 min)
Permissible ambient conditions	$-40 \dots +80$ °C, 0 ... 100% RH including condensation
<b>Electrical data</b>	
Output signal (frequency)	Form rectangle, 1082 Hz @ 50 m/s, supply voltage max. 15 V
Output signal (RS485)	Modbus RTU protocol, bus-compatible Half duplex, data format: 8N1 Baud rate: 2400, 4800, 9600, 19200, 38400, 57600
Electrical supply for optoelec. scanning	Voltage: 3.7 ... 42 VDC (galvanic isolation from housing) Current: typically 14 mA, max. 100 mA (with heating for pressure sensor on) approx. 0,9 mA (power saving mode SM1,HT0)
Electrical supply for heating (only S11200H)	Voltage: 24 V AC/DC (galvanic isolation from housing) Idling voltage: max. 32 VAC, max. 48 VDC Power consumption: 25 W
<b>General</b>	
Connection	8-pole plug-connection for shielded cable in the shaft
Mounting	on mast tube R1" (Outer diameter $\leq 34$ mm, Inner diameter $\geq 22$ mm)
Dimensions	290 x 240 mm
Fixing boring	$\varnothing 35$ x 25 mm
Weight	approx. 0.5 kg
Material	Housing: Anodised aluminium Cup star: Carbon-fibre-reinforced plastic
Type of bearings	Metallic ball bearings
Protection	IP 55 (DIN 40050)
Patent	EP 1 398 637, DE 103 27 632, EP 1 489 427
EMC	EN 61000-6-2, EN 61000-6-3, EN 61010-1, EN 63000 2019-05
Manufacturer	Thies
Accessory	Module set M83575 (incl. isolated repeater)

## Sensor connection to Ammonit Meteo-40 data logger

Sensor	Plug Pin No.	Ammonit Cable Wire Colour	Meteo-40	Supply Sensor
Pulse	1	green	CNT	
Data +	5	white	B+	
Data -	4	brown	A-	
Supply +	3	pink		3.7 ... 42 VDC*
GND	2	grey		GND / PAS
Heating	7	red		24 VAC/DC (25 W)
	8	blue		

\* Supply voltage for usage with Meteo-40 data loggers.

Cable type without heating: LiYCY 3 x 2 x 0.25 mm<sup>2</sup>

Cable type with heating wires: LiYCY 4 x 2 x 0.5 mm<sup>2</sup>

## Sensor connection diagram to Ammonit Meteo-40 data logger

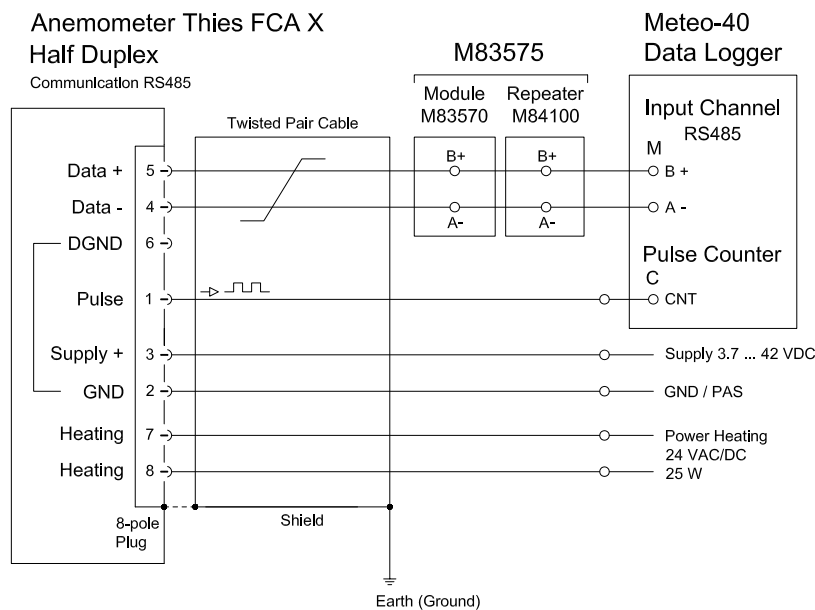

## Connection recommendations for the cable shield

Sensor carrier	Sensor	Shielding / Ground
Metallic met mast, grounded	<b>Non-isolated</b> mounting on the met mast (e.g. by using metallic brackets, holders, etc.)	Connect cable shield <b>only</b> at the side of the data logger to ground.
Metallic met mast, grounded	<b>Isolated</b> mounting at the met mast (e.g. by using non-metallic brackets, holder etc. or metallic brackets, holders etc. with isolated plastic adapters)	Connect cable shield at sensor plug <b>and</b> at the side of the data logger to ground.
Metallic met mast, non-grounded	<b>Non-isolated</b> mounting on the met mast (e.g. by using metallic brackets, holders etc.)	Connect cable shield at sensor plug <b>and</b> at the side of the data logger to ground.

## Plug and cable assembly

### Coupling socket, Type: Binder, Serial 423, EMC with cable clamp

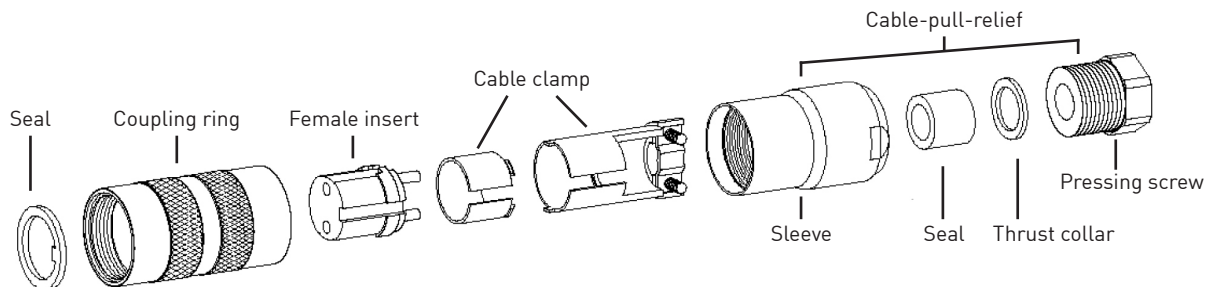

### Cable connection: WITH cable shield

1. Stringing parts on cable acc. to plan given above.
2. Stripping cable sheath 20 mm  
Cutting uncovered shield 15 mm  
Stripping wire 5 mm

A) Putting shrink hose or insulation tape between wire and shield

B) If cable diameter permits, put the shield backward on the cable sheath.

3. Soldering wire to the insert, positioning shield in cable clamp.
4. Screwing-on cable clamp.
5. Assembling remaining parts acc. to plan above.
6. Tightening pull-relief of cable by screw-wrench (SW16 and 17).

A)

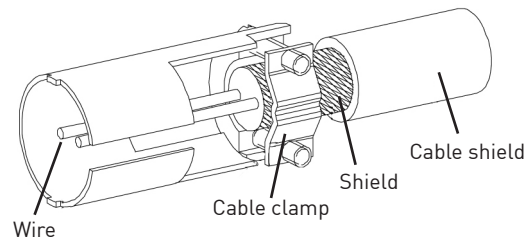

B)

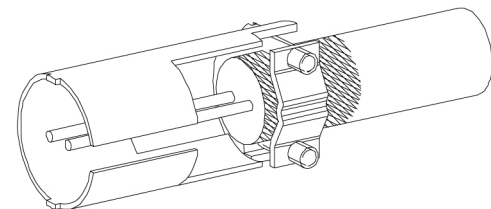

### Cable connection: WITHOUT cable shield

1. Stringing parts on cable acc. to plan given above.
2. Stringing cable sheath 20 mm
3. Cutting uncovered shield 20 mm
4. Stripping wire 5 mm
5. Soldering wire to the insert.
6. Positioning shield in cable clamp.
7. Screwing-on cable clamp.
8. Assembling remaining parts acc. to plan above.
9. Tightening pull-relief of cable by screw-wrench (SW 16 and 17).

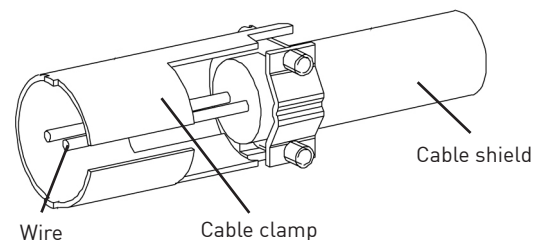

# Anemometer Thies First Class Advanced X

S11201 / S11201H

## Abstract: Summary of cup anemometer classification

According to IEC 61400-12-1 Edition 2.0 [2017-03] Classification Scheme

### Reference:

Deutsche WindGuard Wind Tunnel Services GmbH AK 151023-1.1

Measuring period: 04.2014 - 05.2017

Test site: Varel, Germany

Wind Tunnel: Deutsche WindGuard Wind Tunnel Services GmbH, Varel

## Tilt Angular Response

According to:

- IEC 61400-12-1 Edition 2.0  
Wind Turbine Power Performance Testing 2017-03
- WindGuard Quality System Procedure for Calibration of Wind Speed Sensors at non-horizontal inflow conditions: D 5832

### Result:

Figure showing the of axis response of Thies First Class Advanced X anemometer for wind tunnel speeds of 4 m/s, 8 m/s, 12 m/s and 16 m/s.

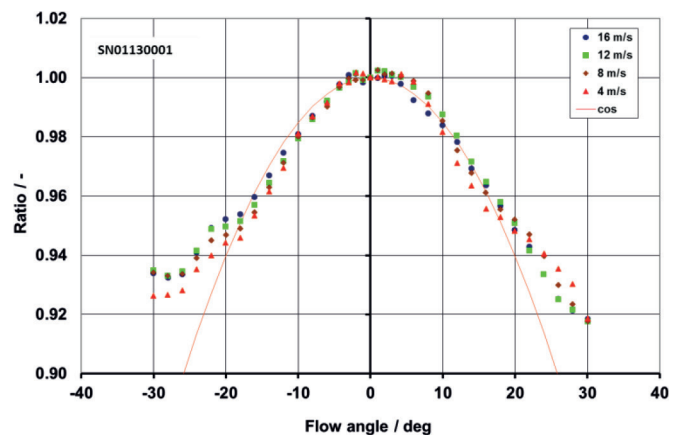

## Class A Classification

According to:

- IEC 61400-12-1 Edition 2.0  
Wind Turbine Power Performance Testing 2017-03

### Influence parameter range:

<b>Wind speed range:</b>	V = 4 ... 16 m/s
<b>Turbulence intensity range:</b>	0.03 - 0.12+0.48/V
<b>Turbulence structure:</b>	1.0/0.8/0.5
<b>Air temperature:</b>	0 ... +40 °C
<b>Air density:</b>	0.9 ... 1.35 kg/m <sup>3</sup>
<b>Flow angle:</b>	-3° ... 3°
<b>Wind simulation:</b>	Kaimal wind spectrum with longitudinal turbulence length scale of 350m

### Result:

Classification Index: **A 0.65** (Internal shaft heating: On)

Classification Index: **A 1.10** (Internal shaft heating: Off)

Source: Summary of Cup Anemometer Classification, Adolf Thies GmbH & Co.KG, Deutsche WindGuard Wind Tunnel Services GmbH, Varel, 2017.

